

RECOMMENDED FPC/FFC DIMENSIONS
GENERAL TOLERANCE ±0.1

NOTES:

1. MATERIAL:
 - 1.1 HOUSING: THERMOPLASTIC, HIGH TEMP., UL94V-0.
 - 1.2 ACTUATOR: THERMOPLASTIC, HIGH TEMP., UL94V-0.
 - 1.3 CONTACT: COPPER ALLOY
 - 1.4 FITTING NAIL: COPPER ALLOY
2. FINISH:
 - 2.1 CONTACT: 50u" MIN. NICKEL UNDERPLATING OVERALL. 1: GOLD FLASH PLATING.
 - 2.2 FITTING NAIL: 50u" MIN. NICKEL UNDERPLATING OVERALL. 50u" MIN. MATT TIN PLATING ON SOLDER TAILS(LEAD FREE).
3. REFLOW SOLDER CAPABLE TO 260°C PER ACES SPEC.
4. SPEC. PLS. REFER TO PS-51625-XXXX-XXX
5. PACKAGE PLS. REFER TO 51656-XXXX-02-TRP
6. PART NUMBER

51656-XXX X X-XXX

NO OF CKT	XXX	HOUSING MATERIAL&COLOR	ACTUATOR MATERIAL&COLOR
0: TAPE & REEL 1: TUBE	(00)	HF & BLACK	HF & WHITE

PLATING
1: G/F PLATING(LEAD FREE)

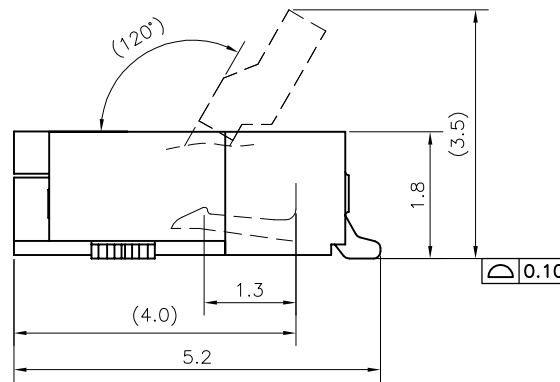
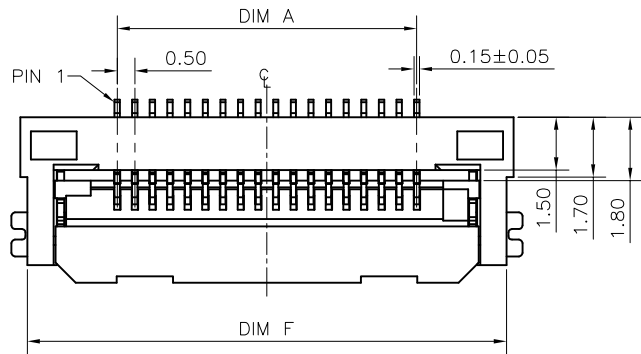

SCALE 6:1

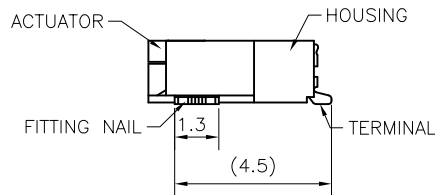
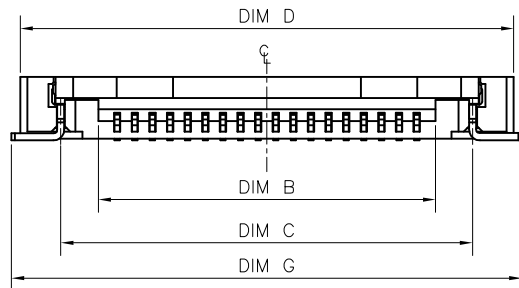
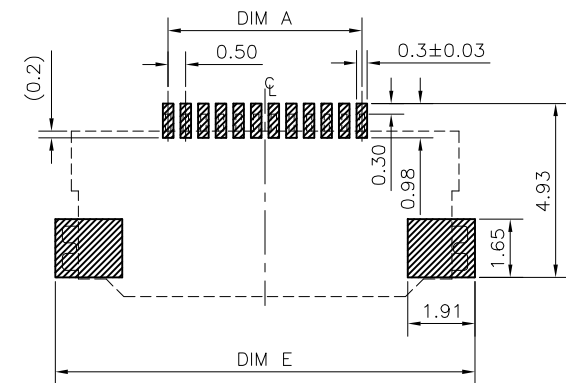

CKT	DIM A	DIM B	DIM C	DIM D	DIM E	DIM F	DIM G
12	5.50	6.57	8.70	11.0	11.9	10.6	11.5

QUALITY SYMBOLS MAJOR Ⓞ CRITICAL Ⓞ GENERAL TOLERANCES (UNLESS SPECIFIED) X. ±0.5 .X ±0.25 .XX ±0.15 .XXX ±0.1 ANGLES ±2°	DRAWN BY	DATE	
	GUOFEI	'21/08/14	
	CHECKED BY	DATE	TITLE 0.5 PITCH EASY ON FPC Conn. H=1.8mm TYPE
	BRAVE	'21/08/14	
	APPROVED BY	DATE	
	BRAVE	'21/08/14	
UNITS		SIZE	DWG NO.
mm		A4	51656-XXXX-XXX
SCALE	SHEET NO.	REV	PART NO.
3:1	1 OF 1	A	SEE NOTES